

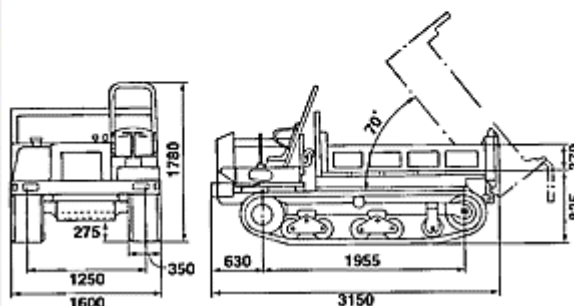

MST Series

- Hydrostatic transmission (H.S.T.) allows for easy usage and efficiency
- Rubber tracks cause minimal damage to fragile soil
- "Boogie" type track rollers
- High traction
- Easy maintenance

MST-300VD

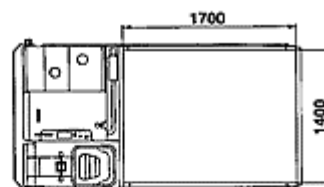

| | |
|--|---------------------|
| Machine weight [kg] | 2,200 |
| Max. payload [kg] | 2,500 |
| Box inner size L x W x H [mm] | 1,700 x 1,400 x 370 |
| Engine | Kubota |
| Model | V2203-B |
| Output / RPM [HP/@RPM] | 46/2,800 |
| Displacement [cc] | 2,197 |
| Transmission | H.S.T |
| Slope climbing unloaded [%] | 57 |
| Ground pressure unloaded [kg/cm ²] | 0.16 |
| Stage 1 speed [km/h] | 6.0 |
| Stage 2 speed [km/h] | 9.0 |
| Length [mm] | 3,160 |
| Width [mm] | 1,640 |
| Height [mm] | 1,620 |